

EASY CUT II

Mähsystem / Cutting system

**John Deere
Kleiner Konus**

(Schwingen Messerantrieb)

2,40 m – 3,00 m

Schnittbreite Cuttingwidth	Standard Part-No.:	Comfort Part-No.:	Premium Part-No.:	Bemerkung comment
2,40 m	17225.01	17225.02	x	
2,70 m	17226.01	17226.02	x	
3,00 m	17227.01	17227.02	x	

Technische Änderungen vorbehalten / Subject to technical alterations.

Diese Ersatzteilliste ist gültig ab: März 2010
This spare part list is valid from: März 2010

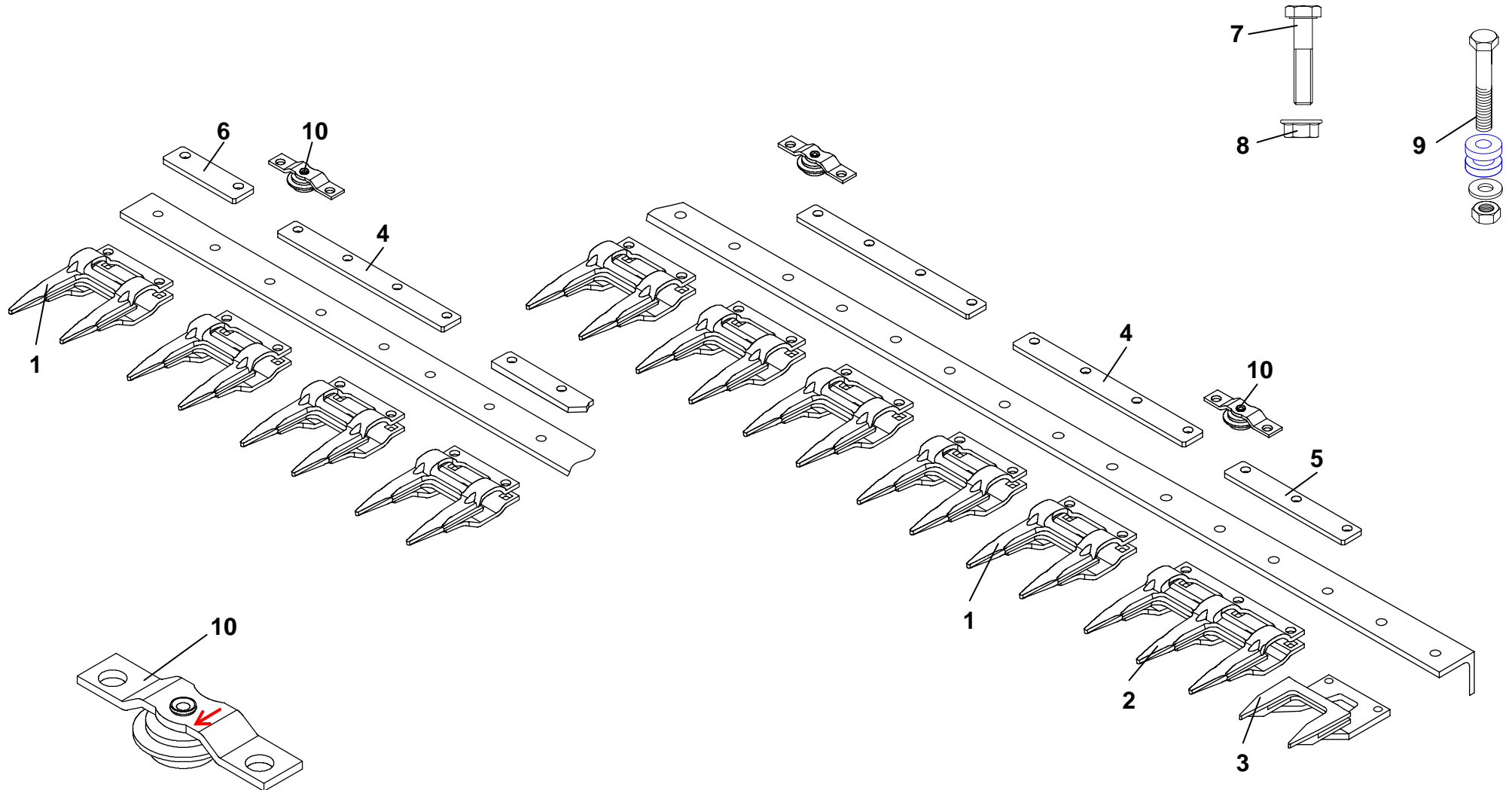

Part No.:16330



John Deere: EASY CUT II Messerantrieb:Schwinge kleiner Konus



Pos.	Art.-Nr.	Bezeichnung	Description	2,40m	2,70m	3,00m						Bemerkungen / Comments
		Standard Ausführung										
1	16500.01	Doppelfinger 12 mm	Guard 12 mm	14	15	18						Plus 1 Ersatzfinger
2	16503.01	Dreifachfinger 12 mm	Triple Guard 12 mm	1	1	1						
3	10701.01	Führungs-Doppelfinger 12 mm	First guard 12 mm open	1	1	1						
4	10743.01	Führungsplatte 6 mm, 4-loch	Spacer bar 6 mm, 4-hole	7	7	9						
5	17016.01	Führungsplatte 6 mm, 3-loch	Spacer bar 6 mm, 3-hole	1	1	1						
6	17013.01	Führungsplatte 6 mm, 2-loch	Spacer bar 6 mm, 2-hole	0	1	0						
7	12997	Schraube M 10 x 40 DIN 933	Screw M 10 x 40 DIN 933	26	27	32						
8	13955	Mutter M10 DIN 6923	Nut M10 DIN 6923	26	27	32						
9	10248	Befestigungselement KM-3	Clamping holder KM-3	7	8	9						
x	14819.01	Reparatursatz	Repair set	1	1	1						
		Comfort Ausführung										
10	16330	Rollenführung		4	4	5						oben führend

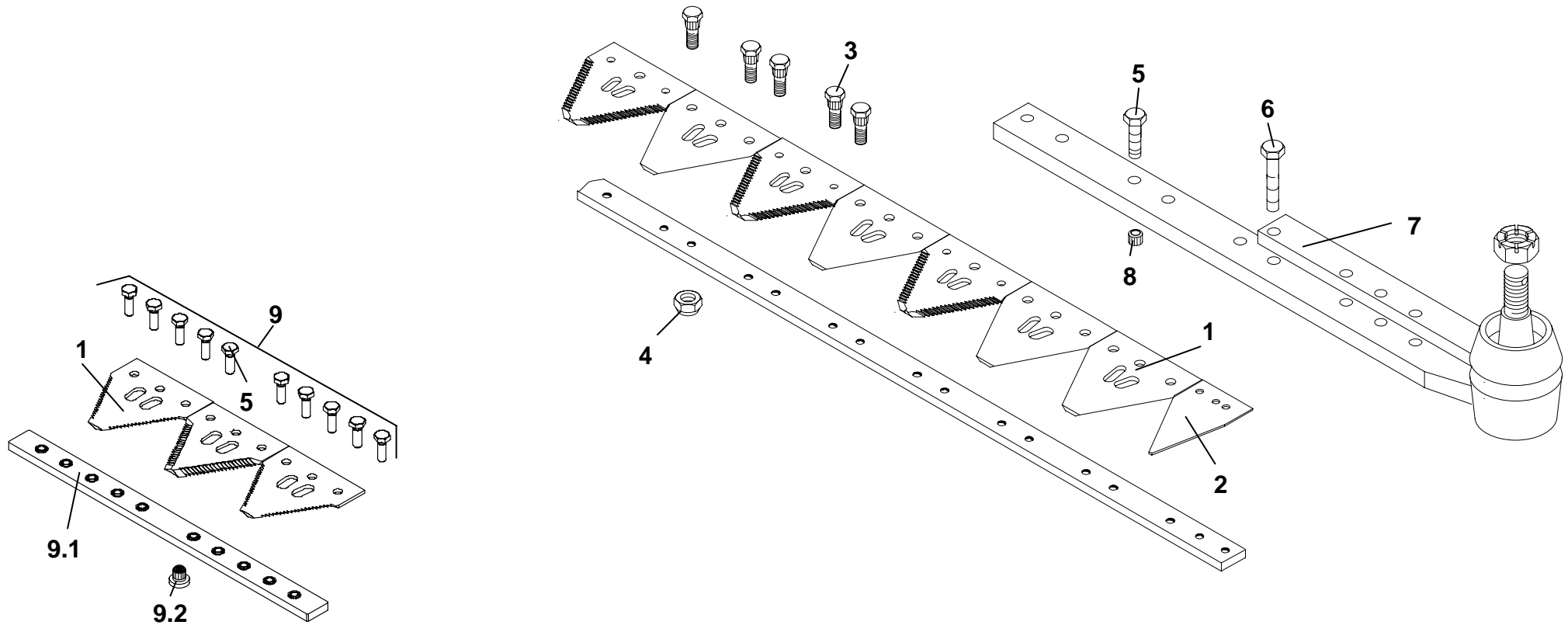



John Deere: EASY CUT II Messerantrieb:Schwinge kleiner Konus

G

Seite 5 von 5
(März 2010)

Pos.	Art.-Nr.	Bezeichnung	Description	2,40m	2,70m	3,00m	Bemerkungen / Comments
1	10966.03	Pro-Cut Messerklinge fein 14 tpi.	Pro-Cut section fine 14 tpi.	33	35	41	Standard/standard
1	10961.03	Pro-Cut Messerklinge grob 11 tpi.	Pro-Cut section coarse 11 tpi.	*	*	*	auf Wunsch/on demand
2	10923.03	Putzklinge Lochabstand 24,7 mm	Half section hole-distance 24,7 mm	1	1	1	
3	10931	Zahnschraube M 6	Toothed screw M 6	51	55	67	
4	13961	Flanschmutter M6	Flange nut M6	51	55	67	
5	10067	Schraube M 6 x 18 10.9	Screw M 6 x 18 10.9	15	15	15	
6	10072	Schraube M 6 x 28 10.9	Screw M 6 x 28 10.9	4	4	4	
7	11267.01	Messerkopf John Deere kl.Konus kpl.	Knife head John Deere cpl.	1	1	1	
8	10941	Einpressmutter Messerkopf	Insert Nut for knife head	9	9	9	
9	16831	Messerverbindung Kit	Knife connector bar kit	1	1	1	
9.1	10134	Messerverbindung	Knife connector bar	*	*	*	
9.2	10937	Einpressmutter Messerverbindung	Insert Nut for Knife conn. bar	10	10	10	
		Messer kpl.	knife cpl.	16936	16937	16938	
	16821	Kopfstück	head pice	1	1	1	
		Mittelstück	middel pice	*	*	*	
		Endstück	end pice	16773	16796	16775	
		Messerrücken lose	knife back				
	16703	Kopfstück	head pice	1	1	1	
		Mittelstück	middel pice	*	*	*	
		Endstück	end pice	16725	16747	16726	