

EASY CUT II

Mähsystem / Cutting system

**John Deere
 (großer Konus)**

Schwingenantrieb

3,00 m – 5,40 m

	Variante / version			
Schnittbreite	Standard	Comfort	Premium	Bemerkung
Cuttingwidth	Part-No.:	Part-No.:	Part-No.:	comment
3,00 m	17069.01	17069.02	17069.03	
3,60 m	17070.01	17070.02	17070.03	
4,20 m	17071.01	17071.02	17071.03	
4,80 m	17072.01	17072.02	17072.03	
5,40 m	17073.01	17073.02	17073.03	

Technische Änderungen vorbehalten / Subject to technical alterations.

Diese Ersatzteilliste ist gültig ab: März 2010
 This spare part list is valid from: March 2010

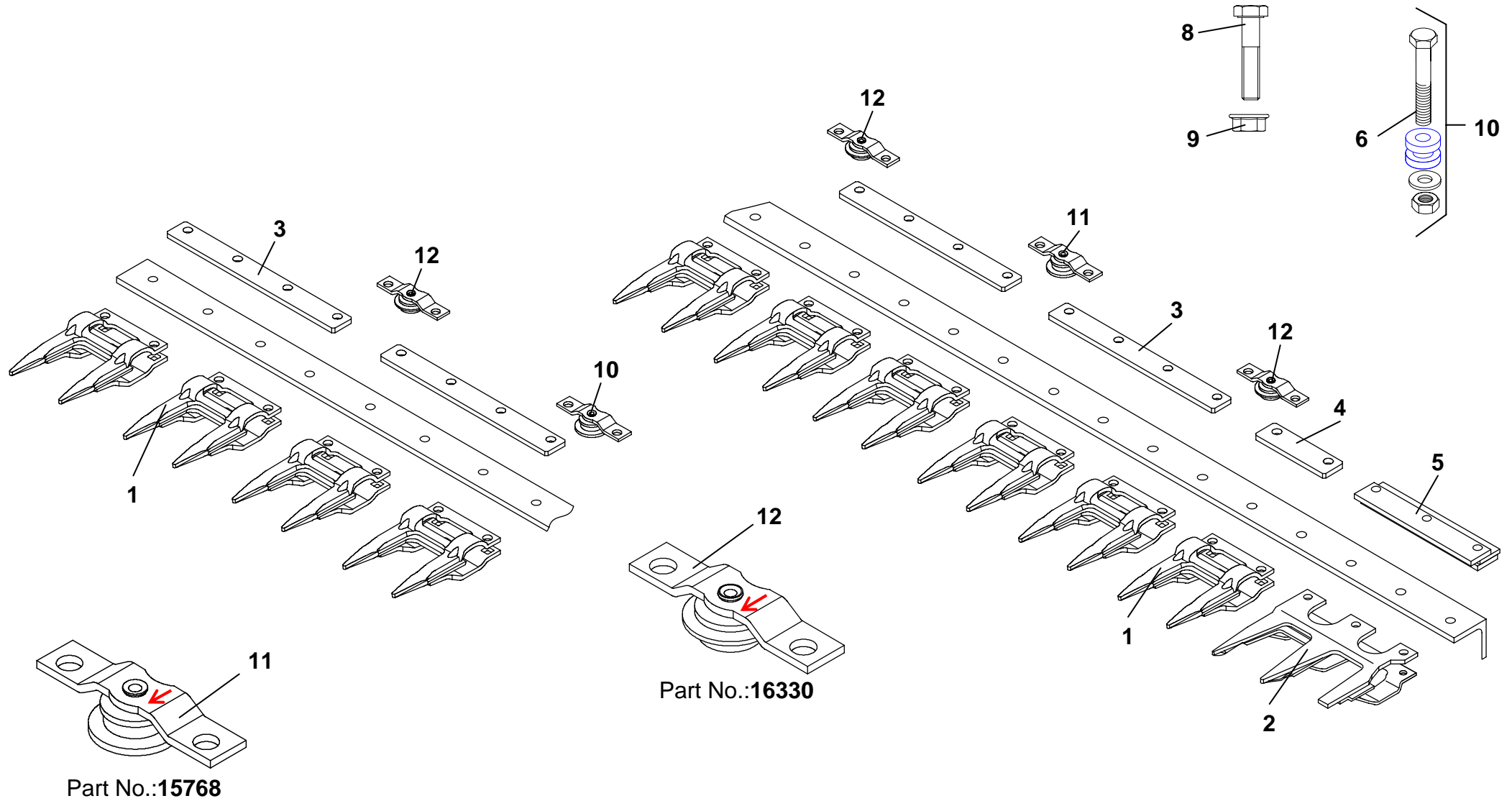



John Deere: EASY CUT II Messerantrieb: Schwinge großer Konus

H

Seite 3 von 5
(März 2010)

Pos.	Art.-Nr.	Bezeichnung	Description	3,00m	3,60m	4,20m	4,80m	5,40m			Bemerkungen / Comments
		Standard Ausführung									
1	16500.01	Doppelfinger 12 mm	Guard 12 mm	19	23	27	31	35			Plus 1 Ersatzfinger
2	10712.01	Führungs-Dreifachfinger 12/22	First triple guard 12/22	1	1	1	1	1			
3	10743.01	Führungsplatte 6 mm, 4-loch	Spacer bar 6 mm, 4-hole	9	11	13	15	17			
4	17013.01	Führungsplatte 6 mm, 2-loch	Spacer bar 6 mm, 2-hole	1	1	1	1	1			
5	10799	Hintere Messerkopfführung 6-4-6	Rear Knife head guiding 6-4-6	1	1	1	1	1			
6	13016	Schraube M 10 x 55	Screw M 10 x 55	3	3	3	3	3			
7	11122	Kugelgelenk John Deere kpl.		1	1	1	1	1			
8	12997	Schraube M 10 x 40 DIN 933	Screw M 10 x 40 DIN 933	29	35	41	47	53			
9	13955	Mutter M10 DIN 6923	Nut M10 DIN 6923	31	38	44	50	56			
10	10248	Befestigungselement KM-3	Clamping holder KM-3	9	11	13	15	17			
x	14819.01	Reparatursatz	Repair set	1	1	1	1	1			
		Comfort Ausführung									
10	16330	Rollenführung		5	6	7	8	9			oben führend
		Premium Ausführung									
11	15768	Rollenführung		4	5	6	7	8			unten führend
12	16330	Rollenführung		5	6	7	8	9			oben führend

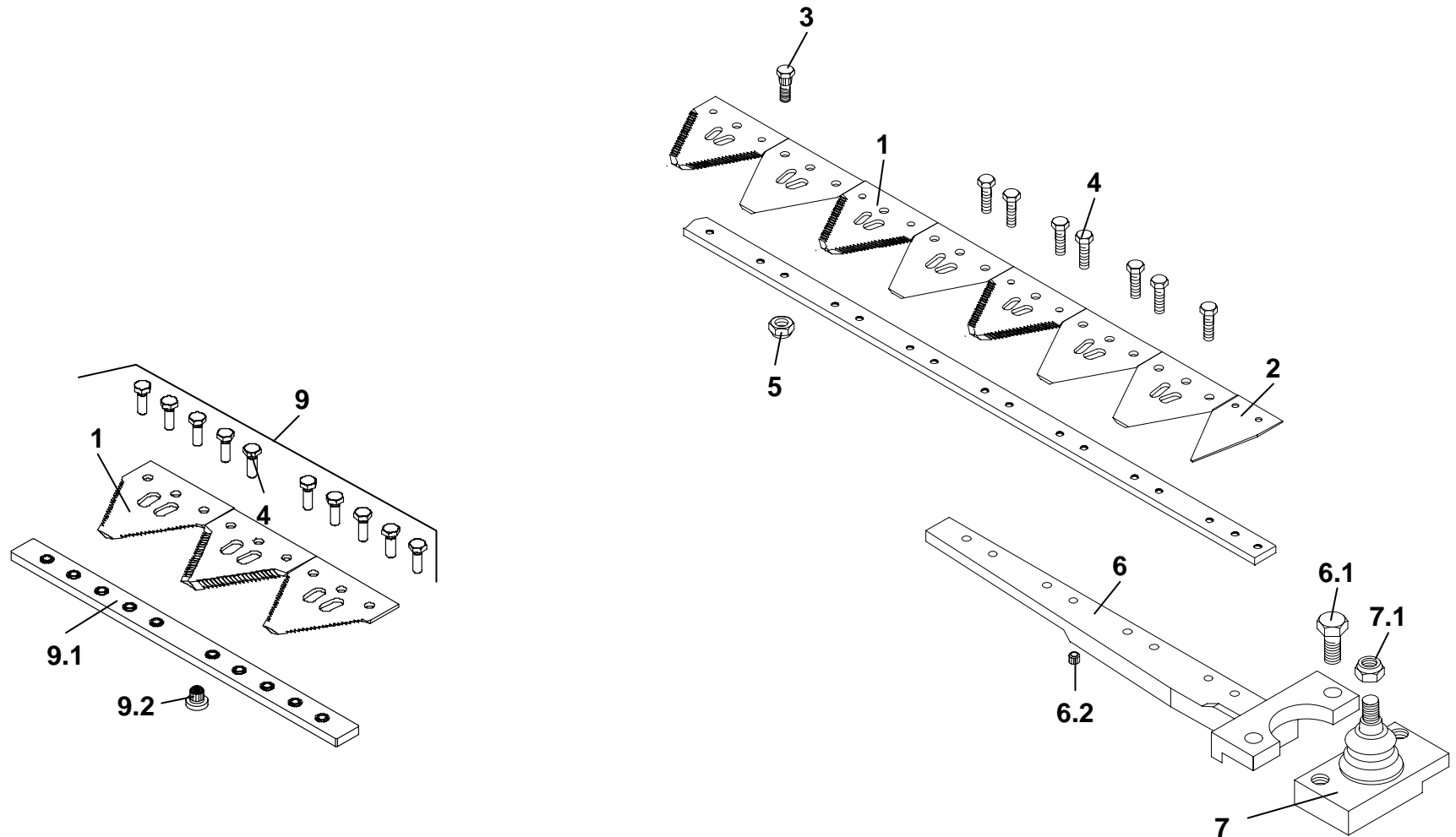



John Deere: EASY CUT II Messerantrieb: Schwinge großer Konus

H

Seite 5 von 5
(März 2010)

Pos.	Art.-Nr.	Bezeichnung	Description	3,00m	3,60m	4,20m	4,80m	5,40m	Bemerkungen / Comments
1	10966.03	Pro-Cut Messerklinge fein 14 tpi.	Pro-Cut section fine 14 tpi.	41	49	57	65	73	Standard/standard
1	10961.03	Pro-Cut Messerklinge grob 11 tpi.	Pro-Cut section coarse 11 tpi.	*	*	*	*	*	auf Wunsch/on demand
2	10923.03	Putzklinge Lochabstand 24,7 mm	Half section hole-distance 24,7 mm	1	1	1	1	1	
3	10931	Zahnschraube M 6	Toothed screw M 6	67	83	91	107	123	
4	10067	Schraube M 6 x 18 10.9	Screw M 6 x 18 10.9	19	19	19	29	29	
5	13961	Flanschmutter M6	Flange nut M6	67	83	91	107	123	
6	11121.01	Messerkopf John Deere gr.Konus (4/8/6.1)	Knife head John Deere cpl.	1	1	1	1	1	
6.1	10035	Schraube M 12 x 25	Screw M 12 x 25	2	2	2	2	2	
6.2	10941	Einpressmutter Messerkopf	Insert Nut for knife head	9	9	9	9	9	
7	11122	Kugelgelenk John Deere kpl.	Socket joint John Deere cpl.	1	1	1	1	1	
7.1	10050	Mutter M 16 x 1,5 selbstsichernd	Nut M 16 x 1,5 self-locking	1	1	1	1	1	
9	16831	Messerverbindung Kit	Knife connector bar kit	1	1	1	2	2	
9.1	16134	Messerverbindung	Knife connector bar	1	1	1	2	2	
9.2	10937	Einpressmutter Messerverbindung	Insert Nut for Knife conn. bar	10	10	20	20	20	
		Messer Kpl.	knife cpl.	16940	16941	16942	16943	16944	
	16830	Kopfstück	Head pice	1	1	1	1	1	
	16758	Mittelstück	Middel pice	*	*	*	1	1	
		Endstück	End pice	16775	16776	16777	16773	16775	
		Messerrücken lose	Knife back						
	16703	Kopfstück	Head pice	1	1	1	1	1	
	16704	Mittelstück	Middel pice	*	*	*	1	1	
		Endstück	End pice	16726	16727	16724	16725	16726	