

EASY CUT II

Mähsystem / Cutting system

IHC-Axial (Freeflow)

Schneidwerk 1030

3,70 m – 7,20 m

Schnittbreite	Standard	Comfort	Premium	Bemerkung
Cuttingwidth	Part-No.:	Part-No.:	Part-No.:	comment
3,70 m	17059.01	17059.02	17059.03	
4,30 m	17060.01	17060.02	17060.03	
4,95 m	17061.01	17061.02	17061.03	
5,55 m	17062.01	17062.02	17062.03	
6,15 m	17063.01	17063.02	17063.03	
6,75 m	17064.01	17064.02	17064.03	
7,32 m	17065.01	17065.02	17065.03	

Technische Änderungen vorbehalten / Subject to technical alterations.

Diese Ersatzteilliste ist gültig ab: März 2010
This spare part list is valid from: März 2010

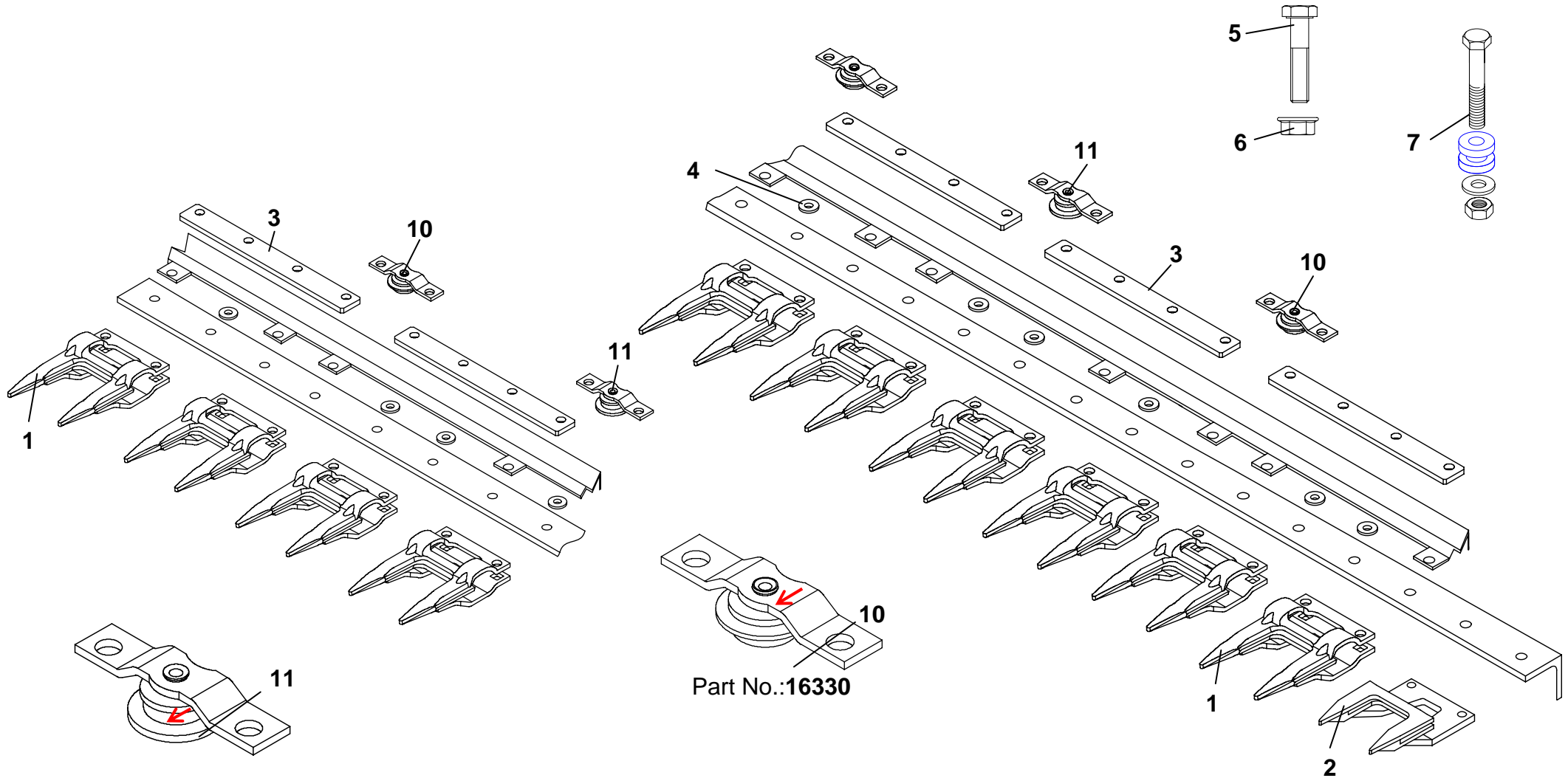

Part No.:15768

Part No.:16330



IHC/Axial: EASY CUT II SW: Freeflow Typ 1030 / Messerantrieb: Ölbad



Pos.	Art.-Nr.	Bezeichnung	Description	3,70m	4,30m	4,95m	5,55m	6,15m	6,75m	7,32m	Bemerkungen / Comments
		Standard Ausführung									
1	16501.01	Doppelfinger 14 mm	Guard 14 mm	24	28	32	36	40	44	48	Plus 1 Ersatzfinger
2	10702.01	Führungs-Doppelfinger 14 mm	First guard 14 mm open	1	1	1	1	1	1	1	
3	10742.01	Führungsplatte 5 mm, 4-loch	Spacer bar 5 mm, 4-hole	12	14	16	18	20	22	24	
4	13452	U-Scheibe 13 x 1,5	Plain washer 13 x 1,5	24	28	32	36	40	44	48	
5	12997	Schraube M 10 x 40 DIN 933	Screw M 10 x 40 DIN 933	39	45	51	57	63	69	75	
6	13955	Mutter M10 DIN 6923	Nut M10 DIN 6923	39	45	51	57	63	69	75	
7	10248	Befestigungselement KM-3	Clamping holder KM-3	11	13	15	17	19	21	23	
x	14819.01	Reparatursatz	Repair set	1	1	1	1	1	1	1	
		Comfort Ausführung									
10	16330	Rollenführung		6	7	8	9	10	11	12	oben führend
		Premium Ausführung									
11	15768	Rollenführung		5	6	7	8	9	10	11	unten führend
10	16330	Rollenführung		6	7	8	9	10	11	12	oben führend

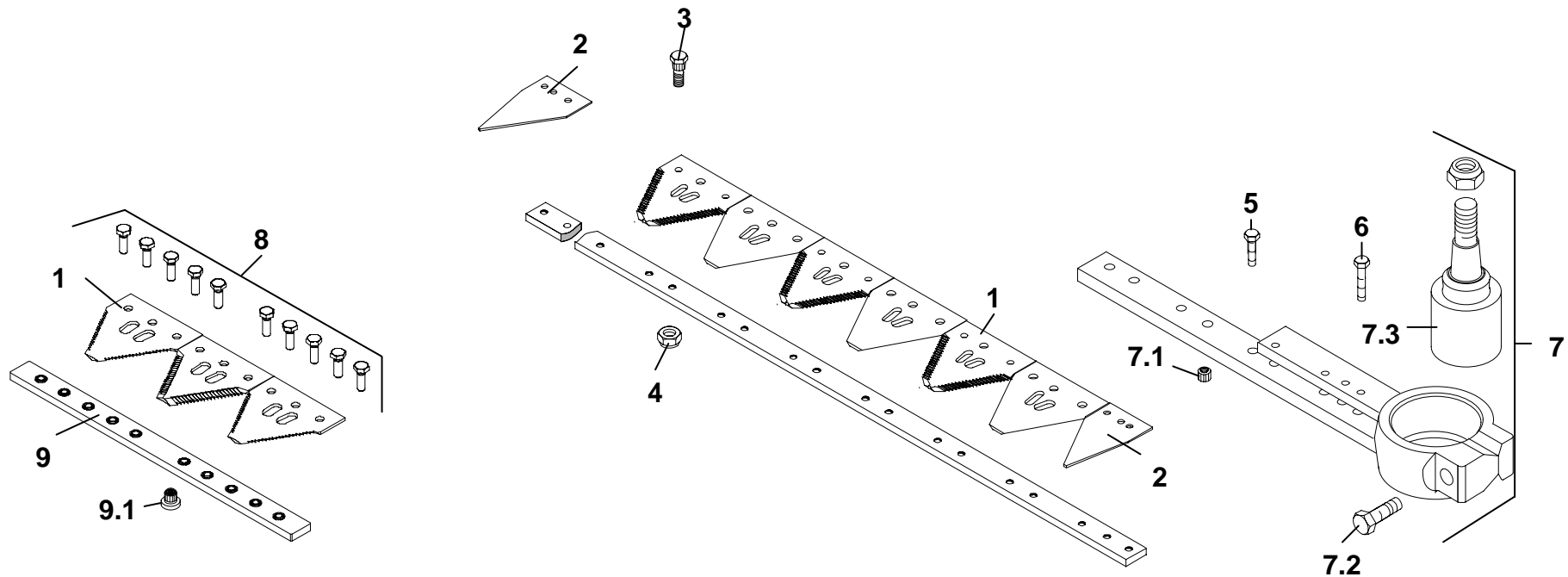



IHC/Axial: EASY CUT II SW: Freeflow Typ 1030 / Messerantrieb: Ölbad



Pos.	Art.-Nr.	Bezeichnung	Description	3,70m	4,30m	4,95m	5,55m	6,15m	6,75m	7,32m		Bemerkungen / Comments
1	10966.03	Pro-Cut Messerklinge fein 14 tpi.	Pro-Cut section fine 14 tpi.	49	57	65	73	81	89	97	101	Standard/standard
1	10961.03	Pro-Cut Messerklinge grob 11 tpi.	Pro-Cut section coarse 11 tpi.	*	*	*	*	*	*	*	*	auf Wunsch/on demand
2	13935.01	Putzklinge Lochabstand 24,7 mm	Half section hole-distance 24,7 mm	2	2	2	2	2	2	2	2	
3	10931	Zahnschraube M 6	Toothed Screw M 6	85	93	109	125	141	149	165	173	
4	13961	Flanschmutter M6	Flange nut M6	85	93	109	125	141	149	165	173	
5	10067	Schraube M 6 x 18 10.9	Screw M 6 x 18 10.9	15	15	23	23	23	23	35	35	
6	10072	Schraube M 6 x 28 10.9	Screw M 6 x 28 10.9	4	4	4	4	4	4	4	4	
7	11305.01	Messerkopf IHC 1030 117 mm	Knife head IHC 1030 117 mm	1	1	1	1	1	1	1	1	
7.1	10941	Einpressmutter Messerkopf	Insert Nut for Knife head	12	12	12	12	12	12	12	12	
7.2	13391	Schraube M 10 x 45	Screw M 10 x 45	1	1	1	1	1	1	1	1	
7.3	16327	Konuskugelgelenk	con adapter cpl.	1	1	1	1	1	1	1	1	
8	16831	Messerverbindung Kit	Knife connector bar kit	1	1	2	2	2	2	3	3	
9	16134	Messerverbindung	Knife connector bar	1	1	2	2	2	2	3	3	
9.1	10937	Einpressmutter Messerverbindung	Insert Nut for Knife conn. bar	10	10	20	20	20	20	30	30	
		Messer kpl.	Knife cpl.	16945	16947	16949	16951	16953	16955	16956	16957	
	16823	Kopfstück	Head pice	1	1	1	1	1	1	1	1	
	16759	Mittelstück	Middel pice	*	*	1	1	1	1	2	2	
		Endstück	End pice	16787	16788	16789	16797	16787	16788	16789	16798	
		Messerrücken lose	Knifeback									
	16703	Kopfstück	Head pice	1	1	1	1	1	1	1	1	
	16704	Mittelstück	Middel pice	*	*	1	1	1	1	2	2	
		Endstück	End pice	16737	16738	16739	16711	16737	16788	16789	16798	