

EASY CUT II

Mähsystem / Cutting system

**MF-Fendt
Powerflow**

Ölbad Messerantrieb

3,70 m – 7,60 m

	Variante / version			
Schnittbreite	Standard	Comfort	Premium	Bemerkung
Cuttingwidth	Part-No.:	Part-No.:	Part-No.:	comment
3,70 m	17074.01	17074.02	17074.03	117 mm
4,30 m	17075.01	17075.02	17075.03	117 mm
4,95 m	17076.01	17076.02	17076.03	117 mm
5,55 m	17077.01	17077.02	17077.03	117 mm
6,15 m	17078.01	17078.02	17078.03	117 mm
6,75 m	17079.01	17079.02	17079.03	117 mm
7,32 m	17080.01	17080.02	17080.03	117 mm
7,60 m	17081.01	17081.02	17081.03	117 mm

Technische Änderungen vorbehalten / Subject to technical alterations.

Diese Ersatzteilliste ist gültig ab: März 2010
This spare part list is valid from: March 2010

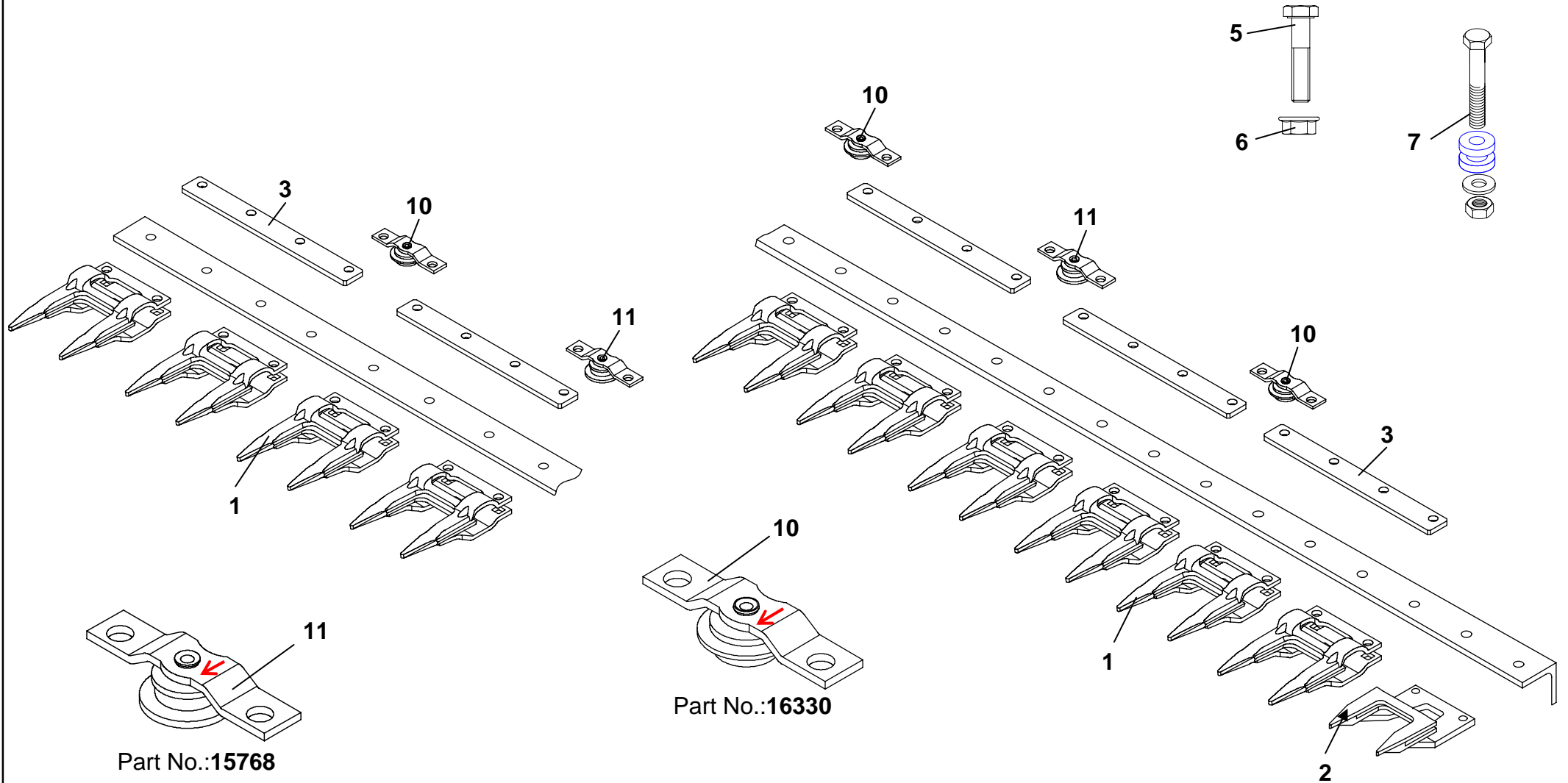

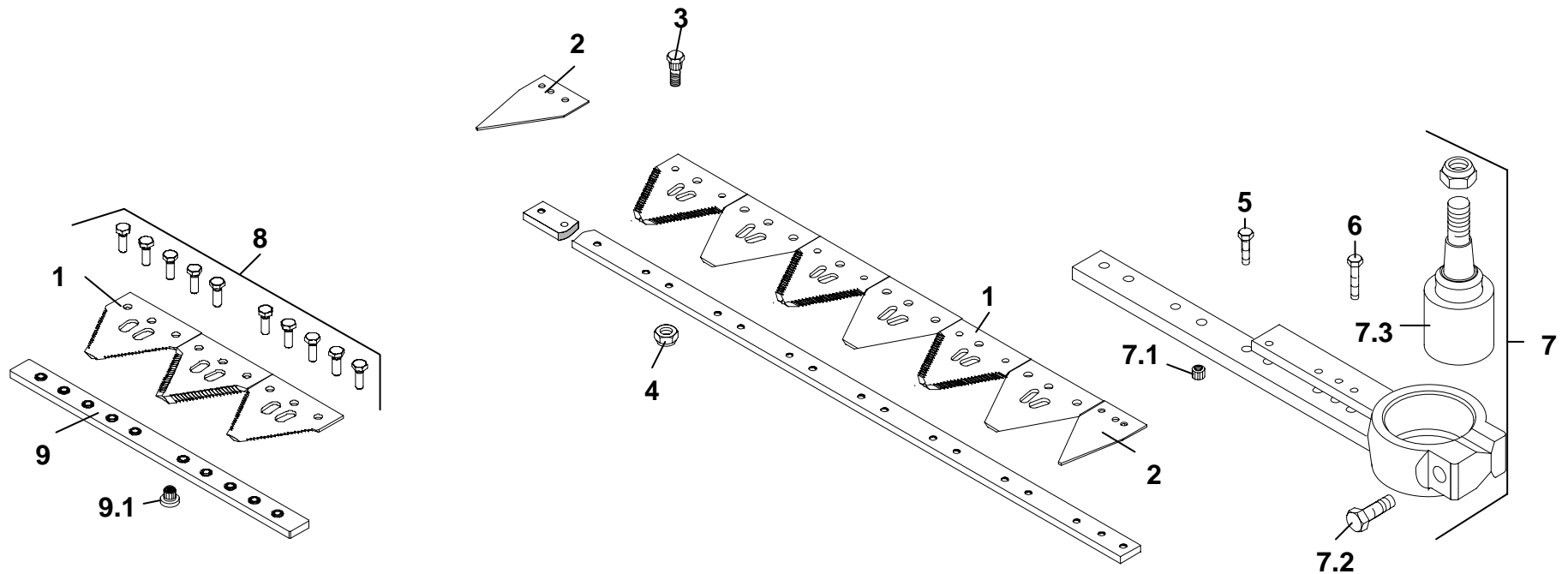



MF / Fendt: EASY CUT II SW: Powerflow bis 2007 Messerantrieb: Ölbad

T

Seite 5 von 5
(März 2010)

Pos.	Art.-Nr.	Bezeichnung	Description	3,70m	4,30m	4,95m	5,55m	6,15m	6,75m	7,32m	7,60m	Bemerkungen / Comments
1	10966.03	Pro-Cut Messerklinge fein 14 tpi.	Pro-Cut section fine 14 tpi.	49	57	65	73	81	89	97	101	Standard/standard
1	10961.03	Pro-Cut Messerklinge grob 11 tpi.	Pro-Cut section coarse 11 tpi.	*	*	*	*	*	*	*	*	auf Wunsch/on demand
2	13935.01	Putzklinge Lochabstand 24,7 mm	Half section hole-distance 24,7 mm	2	2	2	2	2	2	2	2	
3	10931	Zahnschraube M 6	Toothed Screw M 6	85	93	109	125	141	149	165	173	
4	13961	Flanschmutter M6	Flange nut M6	85	93	109	125	141	149	165	173	
5	10067	Schraube M 6 x 18 10.9	Screw M 6 x 18 10.9	15	15	23	23	23	23	35	35	
6	10072	Schraube M 6 x 28 10.9	Screw M 6 x 28 10.9	4	4	4	4	4	4	4	4	
7	17206.02	Messerkopf MF-Dro. Powerflow kpl. 117 mm	Knife head MF-Dro. Powerflow cpl.	1	1	1	1	1	1	1	1	kpl.mit 16327
7.1	10941	Einpressmutter Messerkopf	Insert Nut for Knife head	12	12	12	12	12	12	12	12	
7.2	13391	Schraube M 10 x 45	Screw M 10 x 45	1	1	1	1	1	1	1	1	
7.3	16327	Konuskugelgelenk	cone adapter cpl.	1	1	1	1	1	1	1	1	enthalten in 17206.02
8	16831	Messerverbindung Kit	Knife connector bar kit	1	1	2	2	2	2	3	3	
9	16134	Messerverbindung	Knife connector bar	1	1	2	2	2	2	3	3	
9.1	10937	Einpressmutter Messerverbindung	Insert Nut for Knife conn. bar	10	10	20	20	20	20	30	30	
		Messer kpl.	Knife cpl.	16945	16947	16949	16951	16953	16955	16956	16957	
	16823	Kopfstück	Head pice	1	1	1	1	1	1	1	1	
	16759	Mittelstück	Middel pice	*	*	1	1	1	1	2	2	
		Endstück	End pice	16787	16788	16789	16797	16787	16788	16789	16798	
		Messerrücken lose	Knifeback									
	16703	Kopfstück	Head pice	1	1	1	1	1	1	1	1	
	16704	Mittelstück	Middel pice	*	*	1	1	1	1	2	2	
		Endstück	End pice	16737	16738	16739	16711	16737	16788	16789	16798	